



prodigy[®] 3

gas storage specifications

thinkeasyinstall

A low cost installation offer

thinkvalue

Now with a 7 year tank warranty



1300 365 116

www.dux.com.au

prodigy[®] 3 gas storage

Why you should choose a Dux Prodigy[®] 3 gas storage system

- Backed by a 7 year tank warranty, including 1 year parts and labour
- 3 star efficiency
- Full mains pressure to all taps
- Easy installation – water connections on both sides of tank
- Adjustable thermostat for safety, efficiency and control over operating costs and performance
- Rapid reheat
- Duro-name[®] tank lining for corrosion protection
- Dux is part of a publicly listed Australian company



Which Dux gas storage system is right for you?

CAPACITY (LITRES)	PEOPLE
135	3-5
170	4-6

Adult icon can represent dishwasher or washing machine. An adult icon does not represent a spa bath.

SPECIFICATIONS	135S	170S
Nominal Capacity (Litres)	135	170
Water Capacity in First Hour* (Litres)	270	305
Net Weight Empty (kg)	72	86
Relief Valve Pressure (kPa)	1400	1400
Gas Consumption (MJ/hr) – Natural Gas	33	33
Recovery Rate* (45°C rise litre/hr) – Natural Gas	135	135
Energy Star Rating	***	***

* Temperature rise at 45°C and inlet temperature of 15°C using natural gas

NOMINAL DIMENSIONS (MM)	135S	170S
A Overall Height Outdoor	1601	1896
B Hot Water Outlet	1327	1620
C Cold Water Inlet	221	221
Gas Inlet	336	336

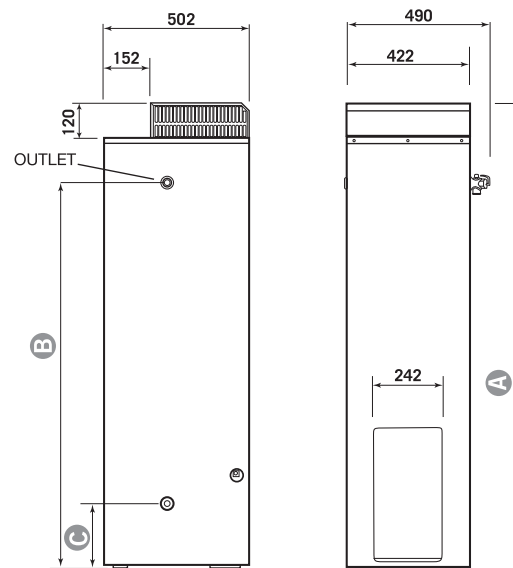

Warranty

Full warranty terms and conditions are in the product's Owner's Manual ("the warranty"), which you must comply with for a warranty claim to be honoured by Dux.

Our goods come with guarantees that cannot be excluded under the Australian Consumer Law. You are entitled to a replacement or refund for a major failure and for compensation for any other reasonably foreseeable loss or damage. You are also entitled to have the goods repaired or replaced if the goods fail to be of acceptable quality and the failure does not amount to a major failure.

Under the warranty, the transport, installation and labour costs of delivering the replacement hot water unit or solar collector and removing and replacing the existing hot water unit or solar collector with the replacement hot water unit or solar collector will be your responsibility, unless otherwise agreed by Dux. The benefits provided to you by the warranty are in addition to the guarantees and other rights and remedies available to you under the Australian Consumer Law.

How to Make a Warranty Claim

Warranty claims can be made at the point of sale or by posting or faxing a warranty claim to the manufacturer (contact details listed below) within one (1) month of the appearance of a defect. Warranty claims must include the following details: date of purchase, location of purchase, proof of purchase, date of installation, contact details, and product serial number.

Manufacturer's Contact Details

Address: Dux Manufacturing Limited, Lackey Road, Moss Vale, NSW, 2577, Australia • Telephone: 1300 365 115 (Australia), 0800 729 389 (New Zealand) • Email: marketing@dux.com.au



Contact Dux for your Hot Water Solutions

Sales: 1300 365 116 Service: 1300 365 115 Web Site: www.dux.com.au

©Dux Manufacturing Limited ABN 19 077 879 844. Lackey Rd, PO Box 209 Moss Vale, NSW 2577

The information supplied was correct at time of printing. Specification and materials may change without notice.

© and ™ indicate trademarks of Dux Manufacturing Limited. Dux Manufacturing Limited is part of a publicly listed Australian company.



GWA
Smarter Solutions