



# Owner's Manual

## **sunpro<sup>®</sup> 305**

### **(Gas Pre-Boost) Solar Water Heater**

Model: 170FNS



Installation Details

Owner's Information

Warranty

For advice, repairs and service, call:

1300 365 115 (Australia)

0800 729 389 (New Zealand)



Carefully remove all packaging and transit protection from the heater before installation. Dispose of the packaging responsibly using re-cycling facilities where they exist.

Specifications and materials may change without notice.  
Effective for Sunpro 305 water heaters manufactured and sold after 1st December 2007.



# Contents

|  |    |
|--|----|
| Welcome To Dux Hot Water                     | 1  |
| Installation Details – Tank                  | 2  |
| Installation Details                         | 3  |
| Plumbing Connections                         | 4  |
| Specifications                               | 7  |
| Installation of Collectors                   | 8  |
| Plumbing Connections –<br>Collectors         | 12 |
| Plumbing Connections –<br>Tank To Collectors | 14 |
| Gas Connections                              | 16 |
| Electrical Connections                       | 18 |
| Hotlogic Connections                         | 19 |
| Commissioning Adjustments                    | 20 |
| Owner's Information                          | 22 |
| System Maintenance                           | 27 |
| Troubleshooting                              | 28 |
| Warranty                                     | 30 |
| Warranty Card                                | 33 |



Owner's Manual – Sunpro 305

## Welcome To Dux Hot Water

Your decision to purchase a Dux Hot Water system will reward you for many years to come.

Since 1915, the Dux range has seen continuous research and development, resulting in many breakthroughs in the efficiency, reliability and longevity of hot water systems.

Dux water heaters are manufactured in Australia in a state-of-the-art facility, using a Quality Endorsed Company production system.

This is your assurance that you have purchased the highest quality water heater available, one that will provide continuous hot water for all your needs – safely, economically, and for many years to come.

To be upfront about it, we want Dux to be your brand of choice. So you can depend on us to provide more than just a hot water system.

You can rely on Dux products and choose them with confidence. We'll make sure you have the information, the quality and the innovation you're looking for, including the latest energy-saving alternatives. If you should ever have a problem – and we'll bet you won't – you'll find that we're easy to get hold of, friendly to talk to and quick to act. Our service is all about providing anything you need as soon as you need it.

Go with Dux and you'll have a dependable, economical, efficient hot water system designed to perform well, year after year. And that's a promise.





## Installation Details – Tank

### Installer's Guide

Full and detailed installation instructions are in the *Installer's Guide*, included inside the water heater's carton.

### Outdoor Tank Installation

The water heater must be installed outdoors, with the minimum clearances as shown in the figure below.

### We recommend a plinth be installed under the water heater where the water heater is subjected to wet conditions

Minimum clearance around the windows and doors must be maintained – refer to AS 5601.

### Location

The water heater should be located as close as possible to the most frequently used hot water outlet. Ensure that the data label is clearly visible and that there is adequate access for servicing the unit.

**Note:** All models are equipped with a sacrificial anode, accessible through the top cover. Allow 50% of the height of the water heater for clearance above to replace the anode.

A properly drained overflow tray must be used where property damage could occur from water spillage. (See AS/NZS3500.4.2 for further details). Warranty does not cover consequential damage due to heater leakage.

### Safety

This appliance is not intended for use by persons (including children) with reduced physical, sensory or mental capabilities, or lack of experience and knowledge, unless they have been given supervision or instruction concerning use of the appliance by a person responsible for their safety.

Children and animals should be supervised to ensure that they do not interfere with the appliance.

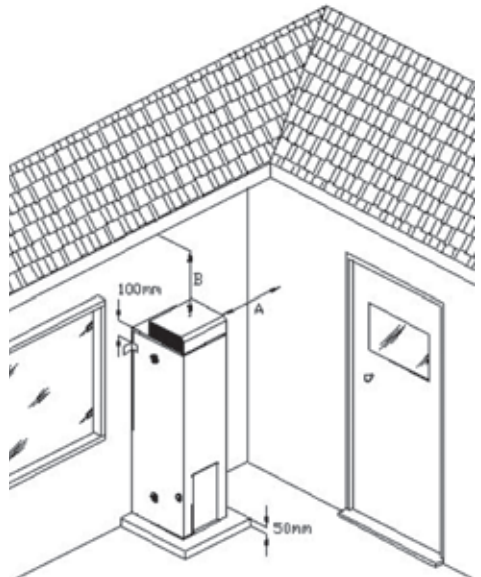

A = 500mm B = 300mm min  
For further details, refer to  
AS 5601 – Gas Installation Code



# Installation Details

## Frost Protection

The areas in gray in the map below may be vulnerable to frost. Solar hot water heaters installed in these areas require an approved antifrost protection device to maximise system performance.



All locations highlighted in gray require an approved antifrost protection device to maximise system performance. Call Dux Hot Water 1300 365 115 for further information.



# Plumbing Connections

## Installation Requirements

This water heater must be installed by a licensed tradesperson, and in accordance with:

- AS/NZS3500.4 “National Plumbing and Drainage Code Hot Water Supply Systems – Acceptable Solutions”.
- AS5601/AG601 “Gas Installations”.
- Local authority regulations.
- Outside Australia and New Zealand, please refer to local plumbing and building codes and regulations.
- Notice to Victorian customers from the Victorian Plumbing Industry Commission – this water heater must be installed by a licensed person as required by the *Victorian Building Act* (1993). Only a licensed person will give you a compliance certificate, showing that the work complies with all the relevant Standards and only a licensed person will have insurance protecting their workmanship for 6 years.

## Water Supply Pressure

This water heater is designed for direct connection to water supply pressures of no greater than:

**1120kPa**

Where the mains pressure can exceed or fluctuate beyond the pressure shown above a pressure limiting device (complying with AS1357) must be fitted in the cold water inlet supply. This device must be installed after the isolating valve and set below the pressure shown above. Note during periods of lower demand water pressure may increase.

**Note:** Plugs are supplied with the water heater to plug off the fittings that are not required. Ensure that a sealing material is applied to the plugs to prevent leaking.

## Pool Heating

This water heater must **not** be used for pool heating.



# Plumbing Connections

## Pressure & Temperature Relief Valve

The Pressure & Temperature Relief (PTR) Valve is supplied loose with the water heater. The valve rating is:

**1400kPa**

The PTR valve must be installed directly into the top socket marked "RELIEF VALVE". The drain line from this valve must run in a continuously downward direction in a frost-free ambient position with the discharge end left open to atmosphere permanently.

The PTR Valve is not intended to enable connection of the water heater to supplementary energy sources such as solar panels or slow combustion stoves (refer AS/NZS 3500.4 for guidance on these types of installations).

Open the PTR Valve for approximately 10 seconds by lifting the lever on the valve to ensure water is relieved to waste through the relief drain pipe. Lower lever gently and check that it closes correctly.

**Warning:** We recommend that you open the PTR valve at least once every six (6) months. Failure to do this may result in problems with the water heater.

The PTR Valve must not be tampered with or removed. The water heater must not be operated unless this valve is fitted and in working order.

The PTR Valve should be checked for adequate performance or replaced at intervals not exceeding 5 years, or less in areas where local regulations apply.

**Important:** The PTR Valve and its drain outlet pipe must not be sealed or blocked. It is normal for the PTR valve to leak a small amount of water during heating cycles.

## Danger

Failure to operate the relief valve easing lever at least once every six (6) months may result in a problem with the water heater and in some cases the tank may explode.

**Warning:** A separate drain line must be run for this relief valve. It is not permitted to couple drain lines from relief valves into a single common drain line.



# Plumbing Connections

## Cold Water Connection

An approved isolating valve, approved non return valve, line strainer (optional but recommended), and union must be fitted between the supply main and the RP $\frac{3}{4}$ "/20 socket in the water heater.

All fittings must be approved by the relevant Authority and in accordance to the plumbing code.

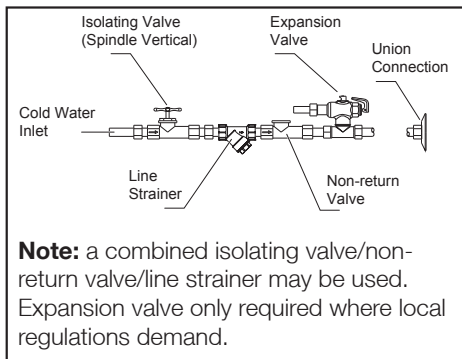

**Note:** a combined isolating valve/non-return valve/line strainer may be used. Expansion valve only required where local regulations demand.

**Note for S.A. and W.A.:** It is a state requirement that a pressure relief valve be fitted on the cold water supply line between the non return valve and the water heater.

## Hot Water Connection

The hot water line should be connected to the "OUTLET" socket on the tank.

## Insulation of Pipes

All hot water pipes **must** be insulated with UV stabilized insulation suitable for solar working temperatures, e.g. Armaflex Insulation.

## Temperature Protection

All solar water heaters have the ability to produce hot water very quickly. To reduce the risk of scald injury, it is mandatory under the requirements of Australian Standard AS/NZS3500.4.2 that a suitably approved temperature control device, such as a tempering valve, be fitted to the hot water supply to outlets used primarily for personal hygiene.

**Note:** This water heater is supplied with a tempering valve. Install the valve according to the manufacturer's recommendations. Any adjustments to the valve should be made according to the manufacturer's recommendations.

The tempering valve should be checked at regular intervals to ensure its operation and settings remain correct.



# Specifications

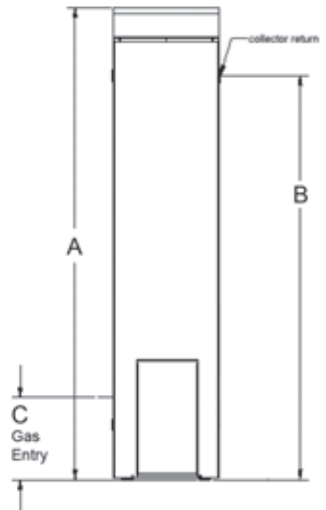
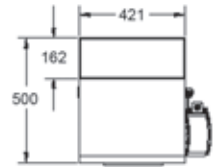
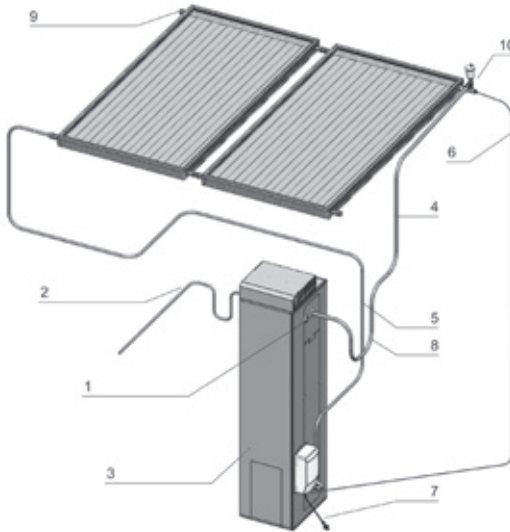

### System Components

| Component | Description                            |
|-----------|--|
| 1         | PTR Valve                              |
| 2         | Hot Water Outlet To House              |
| 3         | Cold Water Inlet (not visible)         |
| 4         | Solar Collector Return                 |
| 5         | Cold Water Outlet To Solar Collector   |
| 6         | Collector Cable                        |
| 7         | Power Supply Cable                     |
| 8         | Heat Trap (300mm Recommended)          |
| 9         | Anti Frost Protection Valve (Optional) |
| 10        | Air Bleed Valve                        |

### Tank Specifications

| Model Numbers | 170FNS |
|---------------|--------|
| Mass (Kg)     | 87     |
| Dimensions    |        |
| A             | 1898   |
| B             | 1622   |
| C             | 330    |
| Baffle Length | 1236   |
| Capacity (L)  | 170    |



# Installation of Collectors

## Installer's Guide

Full installation instructions for the collectors are in the *Installer's Guide*, included inside the water heater's carton.

## Safety

Do not commence an installation until you have satisfied yourself that all safety issues associated with working on and lifting components onto a roof have been addressed.

## Local Authority Regulations

All work associated with the installation must comply with local authority regulations, including AS/NZS 3500.4.2.

Where these installation instructions and local regulations are in conflict, local regulations must prevail.

## Location of Solar Collectors

There are several factors to consider in selecting the collector location site:

- For best performance, the collectors need to face true north. Due to the high solar energy levels experienced in Australia, installations on angles of up to 45° away from true north should not have a major effect on the annual solar output. Consequently, **installations up to 45° away from true north are acceptable**. See Collector Orientation Compass on page 9.
- If the collectors are installed with an east facing bias, the best solar input is achieved in the morning and if there is a west facing bias, the best solar input is in the afternoon.
- The collectors should be installed with a **minimum inclination of 10° and a maximum inclination of 45°**. See Collector Inclination Guide on page 9.
- Careful site inspection is required to ensure the selected location is not subjected to shading from adjacent trees or buildings at any time of the day, but particularly between **9am and 3pm, the highest solar input times**.
- Remember that shadows are longer in winter than in summer, so a site that is free of shadows from adjacent objects in summer may have some shadows in winter.
- To optimise efficiency, the collectors should be as close as possible to the storage tank.
- For best performance, the collectors should be located no more than 20m from the storage tank.
- Ensure that the roof structure is suitable to support the weight of the collectors. The collectors weigh approximately **40kg** each when full.



# Installation of Collectors

## Collector Orientation Compass

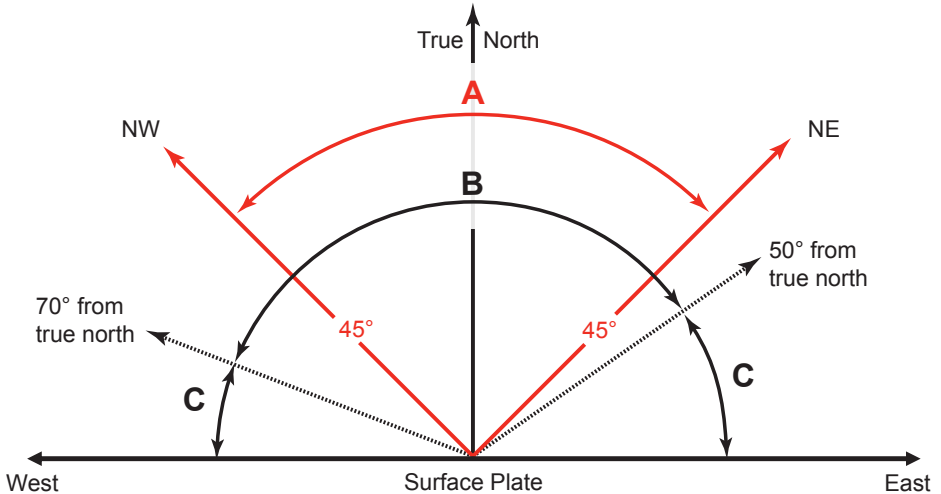

- A. Dux preferred range
- B. Industry accepted range
- C. If orientations A or B are not practical, an additional collector can be installed at the home owner's discretion in range C (not required north of Tropic of Capricorn)

**Note:** When establishing the correct Collector Orientation, please account for the Magnetic Declination of your geographic location

## Collector Inclination Guide

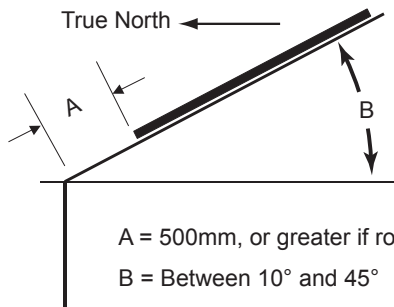

A = 500mm, or greater if roof allows

B = Between 10° and 45°



## Installation of Collectors

### Collector Mounting Kits

The Collector Mounting Kits are designed for mounting the collectors to most common Australian roofing types.

The kit consists of specially designed rails that are bolted to the collector, then fixed to the roof structure using standard roofing screws or bolts.

**Please refer to the collector mounting kit instructions located in the mounting kit box. The mounting kit instructions can also be obtained from Dux Service on 1300 365 115.**

For installations requiring three collectors, an additional Collector Mounting Kit is required as an extension to increase the mounting capacity from two to three collectors.

All kits consist of specially designed rails, clamps and bolts etc. that are used to fix the collectors to the roof structure. With the exception of the copper tube and roofing bolts, these kits contain all of the plumbing components required to connect the collectors to the ground mounted water heater.

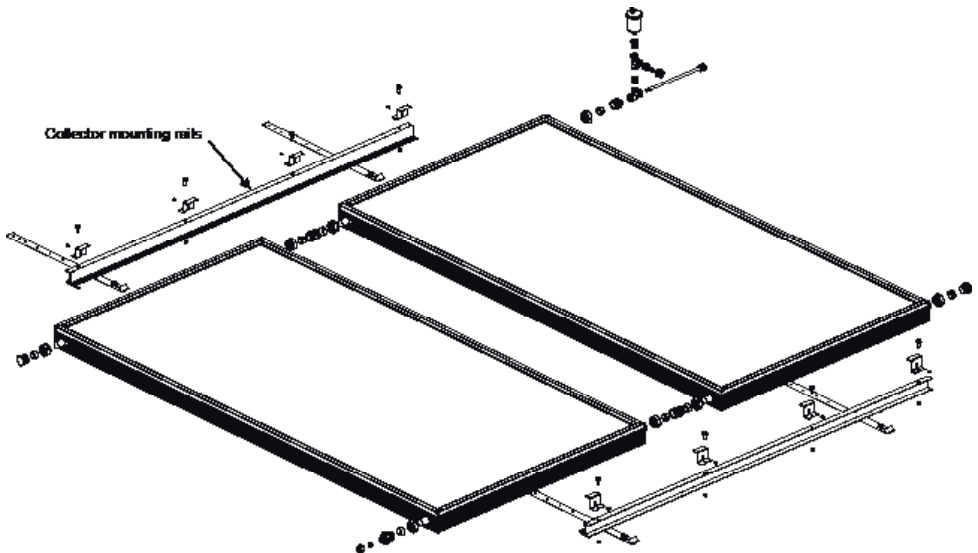



## Installation of Collectors

### Roof Space

It is not advisable to install collectors on roof spaces that are smaller than described below:

- 2 collectors: 3m wide × 3m high
- 3 collectors: 4.5m wide × 3m high

Roof areas smaller than these minimum measurements will make installation and later service work difficult.



## Plumbing Connections – Collectors

### Connections To The Collectors (Open Circuit Systems Only)

Connect the sealing fittings to the four outer connections on the collector array:

1. Fit a sealing washer and plug assembly to the top left and bottom right corners of the array.
  - a. Tighten the assembly taking care not to twist the copper tubes of the collector.
  - b. Ensure you use correctly sized spanners.
2. Screw fit the Air Bleed Valve into the top  $\frac{3}{8}$ " BSP socket and hand tighten until the nylon ring seals against the socket face.

**Important: Please open the knob on top of the valve two turns anti clockwise.**

3. Fit the sealing washer and union base fitting to the top right hand socket of the collector array.
4. Place the Hot Connection Union assembly onto the union base then tighten with the air bleed valve vertical. (NB: The air bleed valve should be at the highest position on the collectors).
5. Finally insert a washer and  $\frac{3}{4}$ " to  $\frac{1}{2}$ " conetite union to the lower left collector socket.

The collector array is now completed and ready for connection to the water heater system.

**Warning:** Copper and brass fittings must be use in all parts of this connection. Plastic fittings and PVC pipes are NOT able to withstand the high temperatures  $>200^{\circ}\text{C}$  that the system can create.

Failure to use fittings with a high temperature rating WILL void the warranty.



# Plumbing Connections - Collectors

| System Components |                       |
|-------------------|-----------------------|
| Component         | Description           |
| 1                 | Air bleed valve       |
| 2                 | Bush                  |
| 3                 | 15mm Female Tee       |
| 4                 | Union 15mm M × 15mm C |
| 5                 | Sensor Dry Well       |
| 6                 | Hex nipple            |
| 7                 | Union 1" C × 1/2" M   |

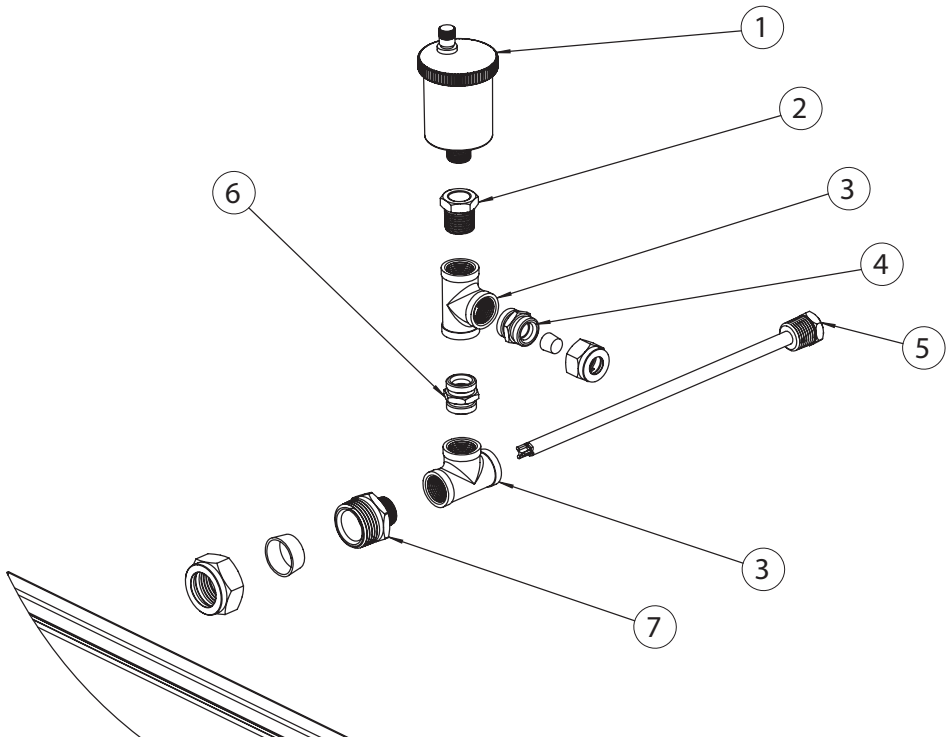
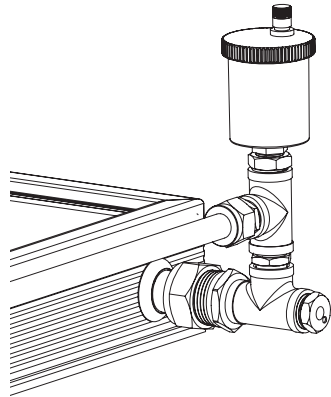



## Plumbing Connections – Tank To Collectors

To make the connection between the solar collector array and the storage tank, the following is required.

1. 2 × ½" (15 mm) copper pipes, run from the collector array down to storage tank.

**Note:** Pipes **must** be insulated with minimum 13mm UV stabilized insulation suitable for solar working temperatures, e.g. Armaflex insulation.

2. 1 × 2 core cable (supplied in kit) run from the collector array to the storage tank.

To complete this connection, do the following:

1. Connect one ½" insulated copper tube to the ½" BSP Compression Union Assembly at the bottom left hand corner of the array and run down to the ground mounted storage tank location. This tube is known as the Collector Cold Connection.
2. Connect the second ½" insulated copper tube to the Hot Connection assembly at the top right hand corner connection of the array and run down to the ground mounted storage tank location. This tube is known as the Collector Hot Connection.

3. Connect the 2 core cable (20 metres – supplied) to the two wires of the BLACK insulated temperature sensor (RED ring around the wire to indicate for hot water). Ensure that the connection is secure and safe. Use a connector block. Insert the temperature sensor into the temperature sensor well of the hot connection union assembly. Fix in place using cable bracket connected to hot connection fitting and seal using a small amount of silicon adhesive/sealant. Run the cable down to the ground mounted storage tank location. (It is important that the sensor cable DOES NOT contact the hot collector return pipe). This sensor is known as the Collector Temperature Sensor. Ensure that the sensor wire does not come in contact with the hot collector return pipe.

**Note:** Care must be taken to ensure that all roof penetrations are sealed to prevent water ingress and to comply with all local regulations.



## Plumbing Connections – Tank To Collectors

### Connections At The Ground Mounted Storage Tank

**Note:** The tank has been pre configured for the hot collector return to be connected to the right hand side of the tank (as marked). The left hand hot outlet is for the hot water supply to the house.

Finally, take the collector temperature sensor cable and pass them through the bottom of the Hotlogic module, then up into the upper section.

Connect the collector temperature sensor cables to the vacant terminals (refer to page 19, Hotlogic Connections).

The polarity of the connections is not important.



## Gas Connections

Gas piping (refer to Data Plate for correct gas type) should be connected through the side of the case (see figure below). The plastic grommet must be installed around the pipe and clipped into the case. The gas control is fitted with a RC $\frac{1}{2}$ /15 socket. A union connection should be used. Pipe sizes should be in accordance with AS5601/AG601.

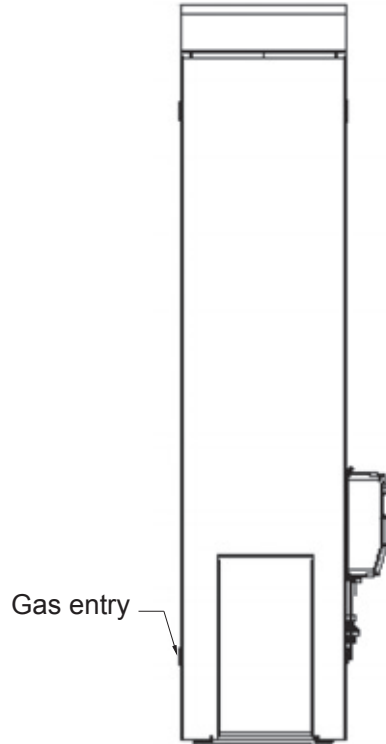





## Electrical Connections

### Electrical Connection

Covers providing access to live electrical parts should be removed only by an electrician.

The electrical power supply switch must be turned off and the fuse removed at the main electrical supply switchboard before any electrical cover is removed.

This water heater is designed for connection to the following:

- Solar Pump Module - CONTINUOUS TARIFF
- Tank Boost - Off Peak, single phase 240V A.C supply

**Note:** This Water heater is also designed to allow the tank boost to be connected to continuous tariff to satisfy heavy daytime users of hot water that exceed the capacity of the off peak boost option.

The electrical connection must comply with Local Supply Authority Regulations and AS3000.

If the power supply lead is damaged, it should be replaced by a lead assembly available only from Dux Manufacturing service agents.

### Note

1. All electrical work must comply with local regulations and be conducted by a licensed electrician.
2. The electrical supply to the pump module must be continuously available. Off Peak power must not be used.
3. Connections are made at terminal block inside the water heater. Entry to connection area is through the hole beneath the element cover, designed to accept a 20mm conduit.



# Hotlogic Connections

## Hotlogic Solar Pump And Controller Module

The Hotlogic box should be plugged in to a weatherproof approved power outlet for 10amps, 230 to 250 volt, 50Hz supply.

The Hotlogic controller must be wired according to the diagram below.

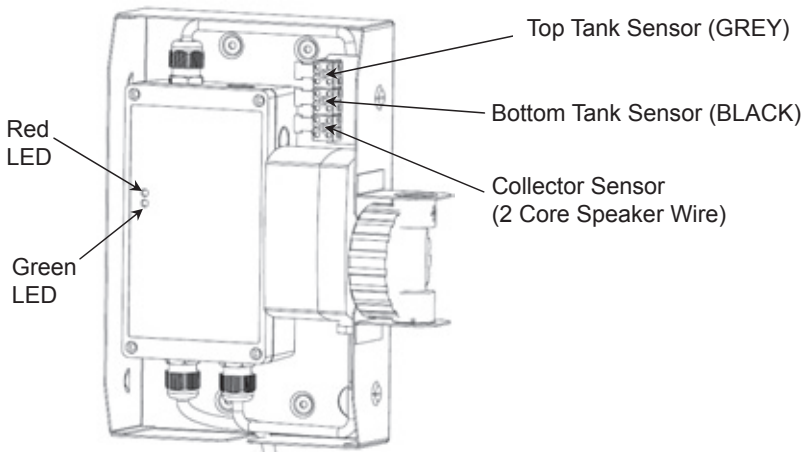

## Hotlogic Diagnosis Codes

| Power LED (Green) | Status LED (Red) | Explanation                                      |
|-------------------|------------------|--|
| Alternating       |                  | Power on initialisation (LEDs blink alternately) |
| On                | Off              | All sensors normal, pump off                     |
| On                | On               | All sensors normal, pump on or booster on        |
| Flashing          | Off              | Sensor error (collector or tank)                 |
| Off               | Flashing         | Tank bottom sensor error                         |
| Flashing          | Flashing         | Tank top sensor error                            |

**Note:** If any sensor is open circuit, the system will indicate a Green only flashing LED.



## Commissioning Adjustments

### Main Gas Pressure Regulator Adjustment

The main burner pressure must be set at installation and should not need readjustment.

The pressure is best checked by connecting a water manometer or equivalent to the test point nipple on the gas control. The test point pressure must comply with the value on the Data Plate.

If adjustment is necessary, proceed as follows:

1. Remove regulator adjustment cap from top of gas control.
2. Remove sealant from adjustment slot if necessary.
3. Light the burner. Rotate adjustment screw clockwise to increase, or anti-clockwise to decrease pressure.
4. Replace regulator adjustment cap.

**Note:** Pressure adjustments at gas cylinder regulator should be conducted as required to ensure correct supply pressure to water heater as per AS5601/AG601.

### Ignition System (Spark Gap)

Check the gap between the spark electrode and the pilot burner is 3 – 5mm and adjust as necessary. Push the igniter button to test for a spark.

**Warning:** test the spark gap only where there is no build up of gas.



## Commissioning Adjustments

### Testing The Water Heater

Test operation by lighting the water heater (see **Lighting the Water Heater**, earlier in this manual). Check that the test point pressure of the water heater complies with the Data Plate. Adjust gas pressure as required to achieve specified gas test point pressure. If problems are encountered in this process contact the Dux Service Department.

**Note:** Instruct owner in water heater operation before leaving.

### Gas Fitter

**Warning:** This water heater should be checked on installation and the test point pressure set in accordance with that marked on Data Plate (see "Testing the Water Heater" in the Installation Details).

Failure to accurately set the pressure can result in damage to the water heater, and automatically cancels the Manufacturer's Warranty. This water heater is to be installed only by an Authorised Person.

### User

**DO NOT** place articles on or against this appliance.

**DO NOT** use store chemicals or flammable materials, or spray aerosols near this appliance.

**DO NOT** operate with panels or covers removed from the appliance.



## Owner's Information

### Operating Instructions

This appliance is not intended for use by persons (including children) with reduced physical, sensory or mental capabilities, or lack of experience and knowledge, unless they have been given supervision or instruction concerning use of the appliance by a person responsible for their safety.

Children and animals should be supervised to ensure that they do not interfere with the appliance.

**Warning:** it is essential for the safe operation of this gas heater that clothing or any other flammable material should not be placed against or on top of the water heater. In addition, do not store flammable or corrosive materials, such as dry cleaning fluids, pool chemicals, etc., in close proximity to the heater.

The use of aerosol sprays in the vicinity of the heater should be avoided. The propellant gases used in these devices, e.g. fly-spray, hair-spray and laundry aids, can break down in the flames of the burner and produce corrosive agents.

**Caution:** If the water heater is left in an operating condition and unused for two weeks or more, a quantity of hydrogen (which is highly flammable) may accumulate in the top of the water cylinder. To dissipate this gas safely it is recommended that a hot tap be turned on for several minutes at a sink, basin or bath, but not a dishwasher, clothes washer or other appliance. During this procedure there must be no smoking, open flame or any other electrical appliance operating nearby. If hydrogen is discharged through the tap it will probably make an unusual sound as with air escaping.

### Maintenance and Repair

Your Sunpro 305 Solar Water Heater is an approved environmental water heater. Operating the water heater outside this condition for a prolonged period of time is a breach of its approval certificate.

The water heater correctly functions using solar gain with a gas booster in case of poor weather.

If for any reason your solar components require maintenance and repair, it is critical that your water heater be repaired as quickly as possible and is returned to its original operating condition and functions as a solar water heater. This includes your solar collectors and their fittings.

It is your responsibility to ensure your Sunpro 305 Solar Water Heater is operating accordingly.



## Owner's Information

### Water Quality

Your Dux water heater has been manufactured to suit water conditions of most Australian metropolitan supplies. Please note that harsh water supplies can have a detrimental effect on the water heater and its life expectancy. If you are unsure about your water quality you can obtain information from your local water supply authority.

The water heater is designed for use in areas where the Total Dissolved Solids (TDS) content of the water supply is less than 2500 mg/L. In areas where the TDS exceeds 600mg/L the magnesium alloy anode (supplied in the heater) may become over reactive. To alleviate this, the anode should be replaced with an aluminium alloy anode, available from your local Dux supplier.

Water can also be very corrosive, measured by the saturation index. If the water saturation index is greater than 0.40 an expansion control valve should be fitted and where the index is greater than 0.80 the water heater installed should be a Hard Water Model. Please consult our Service Department for advice if required.

### How Long Will The Heater Run Each Day?

The length of time that the solar heater will run each day will vary dependent upon the amount of hot water being used by the household and the availability of sunlight to heat the solar collectors.

**Caution:** All water heaters have the ability to produce hot water in a surprisingly short time. To reduce the risk of scald injury, it is mandatory under the requirements of Australian Standards AS3500 that an Australian Standards approved temperature control valve be fitted to the hot water supply pipe work. This valve should be checked at regular intervals to ensure its operation and settings remain correct.



## Owner's Information

### What Should I Do During Holidays?

The system can monitor and control the solar collector temperature while you are away. Whilst the system is safe with the power turned OFF, the collector temperatures can reach very high temperatures, causing high stress to their internal components.

### The power supply to the solar controller Hotlogic pump module must be left ON.

**Warning:** If the hot water system is not used, for two weeks or more, a quantity of hydrogen gas, which is highly flammable, may accumulate in the water heater. To dissipate this gas safely, it is recommended that a hot tap be turned on for several minutes at a sink, basin or bath but not a dishwasher, clothes washer, or other appliance. During this procedure there must be no smoking, open flame or any other electrical appliance operating nearby. If hydrogen is discharged through the tap, it will probably make an unusual noise similar to air escaping.

**Note:** Important there are no user serviceable components in the system. Only an authorised service representative is permitted to remove any covers or make setting adjustments. Do not open or adjust any electrical covers or devices yourself.

### Solar Collector Shading

Trees or buildings can shade the solar collectors, similarly dirt can build up on the glass cover. If this occurs, trees should be trimmed back or the system relocated. If the glass is dirty, it should be cleaned with a domestic glass cleaner – by an authorised tradesperson.

Hot water used in showers, washing machines and dishwashers can be underestimated. Review appliances to determine your daily usage is greater than the storage volume of your water heater.

It is also advisable to inspect tap washers etc. for leakage and replace if necessary.



## Owner's Information

### How Does My System Work?

The main components of your solar water heater are the water storage tank, the solar collector(s), the patented Hotlogic controller and the Ancillary gas booster. The Dux water storage tank is used to store the heated water ready for household use. It is a specific Solar Dux electric storage tank, incorporating a high temperature vitreous enamel lining to provide long life, and a high density polyurethane insulation to ensure minimal heat loss.

The solar collectors contain a multi tube copper water way system bonded to a solar absorber plate, the combination of which collects solar energy and transfers it to the fluid within the collector circuit. The absorber plate system is enclosed in an insulated casing covered with a high strength, low iron glass sheet that protects the absorber system from physical damage.

The Ancillary Energy Support System (Gas boosting – connected to continuous gas supply) is used to heat part of the stored water on those occasions when there is reduced solar energy available. e.g. cloudy days. The AES System is thermostatically controlled so it only delivers the energy required then automatically turns off.

**Never turn the gas supply off during normal use.**

Under normal operating conditions the water within the storage tank is heated by the solar collectors.

In an Open Circuit system, the water is in the collector circuit and the circulating pump draws cold water from the bottom of the tank and pushes it up into the solar collectors. The water is heated in the collector by absorbing heat from the sun and continues on its pumped circulation path back to the top (hot section) of the Dux storage tank, ready for use.



## Owner's Information

### What Does The Circulation Pump Do In The System?

The Circulation Pump is a simple device used to circulate the water in the collector circuit. This, in turn, enables solar energy from the collectors to be transferred to the storage tank location. The pump consumes only a very small amount of electrical energy (less than 28 watts) to perform this task. The circulation pump has an integral 'non-return valve' to prevent solar energy from reverse cycling back through the storage tank to the collectors at night.

The electronic control device used to control the circulation pump has a complex set of activities. It is the brain of the system and ensures optimum system efficiency and safety. The basic functions are:

1. Detecting availability of useful solar energy in the solar collectors. When the temperature of the solar collector is 10°C higher than the storage tank temperature, the circulation pump is initiated. If the difference in temperature falls to less than 2°C the circulation pump is stopped.
2. Controlling maximum storage tank temperature. If the storage tank temperature reaches 85°C, the circulation pump is stopped to prevent excessive temperatures in the storage tank.
3. Frost Protection. When the temperature of ambient conditions adjacent to the collector sensor drops to 5°C the circulation pump will start and run for a minimum of 5 minutes to prevent the collector from freezing. The pump circulates hot water from the storage tank through the collectors until the collector sensor registers that the collector temperature has been raised to 9°C, at which point the pump is shut down.
4. Anti Frost Valve. A secondary level of protection has also been provided through the use of an Anti Frost Valve. This valve opens and releases water from collectors when ambient air temperatures are between below 3°C and 4°C. The valve also isolates the collector and connecting pipework from the tank to prevent the loss of heated water from the tank.



## System Maintenance

The Dux solar water heater is designed such that there is little to do regarding system maintenance other than that detailed in this *Owners Manual*. The components in the solar side of the system do not require maintenance.

Personally inspecting or servicing any part of the system is not recommended.

Should you decide to personally inspect the roof mounted system components, it is essential that you use all safety devices required to ensure your safety.

After each 5 years of operation you should contact the local service agent to replace all safety valves and anodes to ensure continued system life and operational safety. In locations where the water has a TDS greater than 600 ppm, this service is recommended each 3 years.

### **Six Monthly Service – By Owner**

Operate the Pressure & Temperature Relief Valve for approximately 10 seconds by operating the easing lever on the valve to ensure water is relieved to waste through the relief drain pipe. Check to ensure the valve closes correctly.

### **Five Year Service – By Authorised Personnel Only**

The five year service must be carried out by a licensed tradesperson. It is recommended that this service be carried out by your local Dux agent.

The service should include the following:

- Replace the Pressure & Temperature Relief Valve.
- Replace the anodes (in areas of harsh or adverse water conditions, a more frequent check of the anodes is recommended).
- Cleaning of collector panels to improve solar collection.
- Flush the water heater by doing the following:
  - i. Turn off the power.
  - ii. Turn off the cold water supply to the water heater at the isolating valve.
  - iii. Gently operate the easing lever on the Pressure & Temperature Relief Valve to release the pressure in the water heater.
  - iv. Disconnect the cold water inlet union to the heater and attach a drain hose.
  - v. Gently operate the Pressure & Temperature Relief Valve to let air into the heater and allow water to escape through the hose.
  - vi. Flush the heaters until clear water appears then reconnect all fittings, fill the heater and restore the electricity supply.

### **Draining the Water Heater**

To drain the water heater, follow steps i to v above until no more water escapes from the appliance.



## Troubleshooting

### **What Should I Check Before Making A Service Call?**

If there is not enough hot water, it is recommended that the following points be considered before making a service call. If after checking the following points the problem has not been identified, please contact Dux on 1300 365 115.

### **No Hot Water**

- Is the Pressure & Temperature Relief Valve discharging too much water?
- Do you have the correct size water heater for your requirements? Sizing details are available from your Dux supplier.
- Is one outlet (such as the shower) using more hot water than you think?
- Carefully review the family's hot water usage and if necessary check the shower flow rates with a bucket, measuring the amount of water used over that period of time. If it is not possible to adjust water usage patterns, an inexpensive flow control valve can easily be fitted to the shower outlet.
- Consider that during night time heating, the time taken to heat the tank can take longer (less energy in the air) so you may find that the tank has not fully recovered from a period of heavy usage the previous evening.
- Consider that often the hot water usage of showers, washing machines and dishwashers can be under estimated. Review these appliances to determine if your daily usage is greater than the storage volume of your water heater. For example, if you have a 170 litre storage tank and you are using 300 litres of water it is possible that there will be certain times of the day where there is insufficient hot water. It is also advisable to inspect tap washers etc. for leakage and replace if necessary.
- Is there a leaking hot water pipe or dripping hot water tap? A small leak can waste a large quantity of hot water.
- Replace faulty tap washers and have your plumber rectify any leaking pipe work.



## Troubleshooting

### **Water Discharge from the PTR Valve**

#### **Pressure & Temperature Relief Valve (PTR)**

It is normal for the PTR to allow a small quantity of water to escape during the heating cycle. The amount of discharge will depend on hot water usage.

#### **Continuous trickle (PTR)**

This is most likely due to a build up of foreign matter. In this case try gently raising the easing lever on the Pressure & Temperature Relief Valve for a few seconds then release gently. This may dislodge a small particle of foreign matter and rectify the fault.

#### **Steady flow (PTR) – more than 20L per day**

This may be caused by excessive water supply pressure, a faulty Pressure & Temperature Relief Valve or a faulty thermostat. Turn off the electricity supply and contact your Dux Hot Water.

### **Condensation in Collectors**

In winter, or in times of heavy rain, water vapour may form in the warm and humid solar collectors, and then condense on the inside surface of the cold glass.

As solar collectors are insulated for optimum performance and have minimal internal airflow, condensation that has formed during these times takes a longer time to disperse but will do so when enough direct sunlight has come in contact with the collectors. The warmer the sunlight, the faster it will disperse.

Condensation in the collectors does **not** affect the system's performance.



## Warranty

### Dux Hot Water Unit

#### Manufactured by Dux Manufacturing Limited (“Dux”)

#### Terms of Warranty and Replacement Guarantee

All Sunpro 305 gas boosted solar water heaters manufactured and sold after 1 January 2011 are backed by a comprehensive one (1) year full parts and labour warranty (conditions apply – see below).

Furthermore, the Sunpro 305 inner cylinder and solar collectors include a guarantee to replace your hot water unit if the inner cylinder fails within five (5) years and to replace the solar collector if it fails within five (5) years (conditions apply – see below).

The terms of the Warranty and replacement guarantee are set out below.

#### 1 Year Comprehensive Warranty

Your Sunpro 305 hot water system and its components are covered by a one (1) year (parts and labour) warranty against defective factory materials or workmanship from the date your hot water unit or solar collector/s is installed or two (2) years from date of manufacture, whichever occurs first.

#### 5 Year Replacement Guarantee

If an inner cylinder or solar collector

fails on a Dux hot water unit within a further four (4) years after the end of the initial one (1) year warranty period, Dux will provide a free replacement hot water unit and/or solar collector at the nearest approved Dux agent or Dux office to the owner's home. Under this replacement guarantee, the transport, installation and labour costs of delivering the replacement hot water unit and removing and replacing the existing hot water unit will be the responsibility of the owner of the existing hot water unit. Please note that Plumbing regulations require that the replacement collector be re-installed by a licensed Plumber.

#### Scope of Warranty and Replacement Guarantee

In addition to the guarantees implied by the Australian Consumer Law (“ACL”), Dux provides a warranty for the periods of time set out above (1 year plus a further 4 years), after the date of installation (or manufacture) of the hot water heater (“the Unit”), that the Unit is free from all defects in factory materials or workmanship under normal use.

If the Unit fails to conform to this warranty during the applicable period, Dux will replace any failed component or where necessary, in the absolute discretion of Dux, replace the Unit free of charge including reasonable labour costs incurred in normal business working hours.



## Warranty

**Note:** Where the date of completion of installation is not known, then this warranty will commence one (1) month after the date of manufacture (refer to the data label on the Unit).

This warranty only applies to defects which have arisen solely from faulty materials or workmanship in the Unit and does not apply to other defects which may have arisen as a result of, without limitation, the following: accidental damage, abuse, misuse, maltreatment, abnormal stress or strain, harsh or adverse water conditions including excessive water pressure or temperature, or neglect of any kind of the Unit. Alterations or repair of the Unit other than by an accredited and licensed service agent or technician are not covered. Attachment of accessories or use of non genuine replacement parts other than those manufactured or approved by Dux are not covered by this extended warranty.

This warranty applies only to the Unit and does not cover any ancillary plumbing or electrical parts supplied by the installer such as pressure limiting valve, tempering valve, line strainer, stop cocks, non-return valve, electrical switches, pumps or fuses, or faulty installation.

The Unit must be installed by a licensed plumber in accordance with information set out in the Owner's Manual and/ or Installer's Guide supplied with the

Unit and/or any relevant statutory requirements.

In addition to this extended warranty, certain legislation (including the ACL) may give you rights which cannot be excluded, restricted or modified. This extended warranty must be read subject to such legislation and nothing in this warranty has the effect of excluding, restricting or modifying those rights.

If Dux fails to meet a guarantee implied by the ACL, your remedy for such failure may be limited to any one or more of the following:

- replacement of the Unit;
- repair of the Unit;
- refunding the cost of the Unit;
- payment of reasonable costs of having the Unit repaired;
- payment in respect of the reduced value of the Unit.

Any defective part of the Unit must be returned to the point of sale before replacement can be considered under the terms of this warranty. If the costs of returning any defective parts are unreasonable, please contact Dux on 1300 365 115 (Australia) or 0800 729 389 (New Zealand) so that we can arrange a collection if appropriate.

Warranty claims can be made at the point of sale or by posting or faxing a warranty claim to Dux (contact details



## Warranty

listed below) within one (1) month of the appearance of a defect. Warranty claims under this extended warranty must include the following details:

- Date of Purchase;
- Location of Purchase;
- Proof of Purchase;
- Contact Details
- Product Serial Number

### Contact details

Dux' contact details are as follows:

#### Postal Address:

Dux Manufacturing Limited  
PO Box 209  
Moss Vale, NSW, 2577  
Australia

#### Telephone:

1300 365 115 (Australia)  
0800 729 389 (New Zealand)

#### Facsimile:

(61 2) 4868 0257

#### Web:

<http://dux.com.au/>

**Note:** If the Unit is located in a position that does not comply with the installation instructions or relevant statutory requirements, then this extended warranty does not cover major dismantling or removal of cupboards, doors, walls or special equipment and/or excessive labour, at the determination

of Dux, to make the Unit accessible for repair or replacement.

As required by legislation, including under the ACL, any claims for damage to furniture, carpets, walls, foundations or any other consequential loss either directly or indirectly due to defects of any kind in a Unit will only be met by Dux where the damage could be considered reasonably foreseeable.

Our goods come with guarantees that cannot be excluded under the ACL. You are entitled to a replacement or refund for a major failure and for compensation for any other loss or damage. You are also entitled to have the goods repaired or replaced if the goods fail to be of acceptable quality and the failure does not amount to a major failure.



# Warranty Card

Inside the water heater carton you will find a warranty card – please fill in the details and return immediately. This will ensure prompt service under warranty, if required.

Product Warranty is applicable only in Australia and New Zealand.

See page 30 for terms of warranty.

*Privacy Act Amendment (2000):* If and whenever warranty service is required, your personal details will be given to an Authorised Dux Service Agent only for the express purpose of carrying out the arranged warranty service work agreed by you the client and Dux Manufacturing Limited.

### Your Details

For future convenience, fill in the following details and retain with your original invoice for your own records.

Surname:.....Given Name(s):.....

Address:.....

Town/Suburb:.....

State/Territory:..... Postcode:.....

Date of Purchase:..... Purchased From:.....

Model:..... Serial Number:.....

Date of Manufacture:.....

(Details on Data Label on water heater)

### Installer's Details:

Date of Installation:..... Installer's Name:.....

Address:.....

Installer's Signature:.....

### Service Details:

Date of Service:..... Serviced By:.....

Work Carried Out:.....

.....

.....

Signature of Service Agent:.....



Owner's Manual – Sunpro 305

# ***sunpro*<sup>®</sup> 305**

**(Gas Pre-Boost) Solar Water Heater**

For advice, repairs and service, call:

1300 365 115 (Australia)

0800 729 389 (New Zealand)



**GWA**  
*Smarter Solutions*

H3058 10345 Rev. G